

**FXT1.1-SLI-S**

code: 4330 034 10021

13.56 MHz FERROXTAG SCREW BOX

FEATURES

- ISO/IEC 15693; ISO/IEC 18000-3 Compliant
- 13.56 MHz Operating Frequency
- 1024 Bits User Memory in 32 blocks x 4 bytes
- Unique Identifier 8 bytes
- Fast Simultaneous Identification (Anticollision)
- Data transfer up to 53kbits/sec

APPLICATIONS

- Non metal items identification
- Industrial applications
- Asset Tracking
- Wood pallets
- Plastic boxes
- It is specially recommended for applications where humidity and/or liquids are present due to the silicone sealant guaranties its best performance.
- It is recommended the use of FXF1.1-SLI-X epoxy sealed, for applications where the tag has to be glued to the metal item.

DESCRIPTION

FerroxTag 13.56MHz encapsulated on screw box is complaint with the ISO/IES 15693 and ISO/IEC 18000-3 global open standards. This product offers a user accessible memory of 1024 bits, organized in 32 blocks of 4 bytes and an optimized command set.

Each transponder has a factory programmed 8 bytes unique identifier. Prior to delivery, Ferroxtag undergo complete and parametric testing, in order to provide high quality.

Designed for harsh environments, the encapsulation protects the device against impacts, making it ideal for industrial applications operating at high temperatures, high humidity and even inside liquids.

This part is not tuned for use on metallic items. **For metal items use Ferroxtag on metal screw box FXT1.2-SLI-S, or ask your local distributor. www.ferroxtag.com.**

SPECIFICATIONS

PART NUMBER	FXT1.1-SLI-S
Supported Standard	ISO/IEC 15693; ISO/IEC 18000-3
Passive Resonance Frequency (at the air)	13.56 MHz \pm 300 kHz
Unique identifier	8 bytes
EEPROM memory	1024 bits, 32 blocks x 4 bytes
User programmable memory	28 blocks x 4 bytes
Typical programming cycles	100,000
Data retention time	10 years
Data transfer	Up to 53 kbits/sec
Typical reading range	30 cm with 4 watts reader power and 30x30 cm antenna on a metallic item
Simultaneous Identification of Tags	Up to 50 tags per second (reader/antenna dependent)
Operating temperature	-25°C to +130°C
IC	NXP-ICODE SLI



FXT1.1-SLI-S

code: 4330 034 10021

MECHANICAL PROPERTIES

Dimensions	25 x 12.5 x 5 mm
Weight	2.5 grams
Case material	POLYAMIDE 66 UL94-V0
Degree of protection	IP68
Colour	Black, sealed with black silicone
Storage temperature	-40°C to +180°C
Sealing material	Black silicone

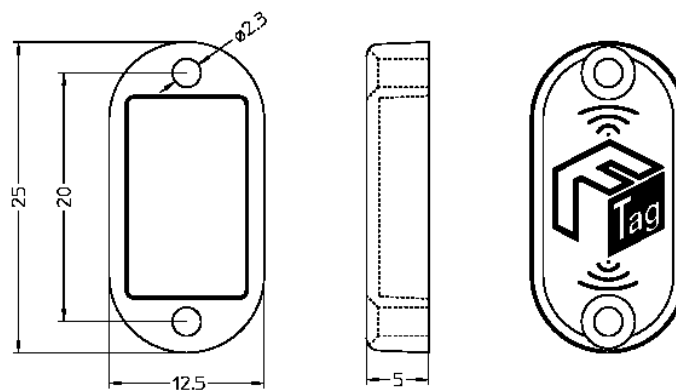

TAG INSTALLATION

It is recommended to install the tag on a corner of the item to be identified, or in the closest position to the reader antenna. Optimal performance is achieved by orientating the device towards the reader as shown in the figure.



The right way of installing the transponder is by screwing the piece placing the silicone part against the item to be identified.

MEMORY ORGANIZATION

The 1024 bits EEPROM memory is divided in 32 Blocks of 4 bytes. (1 Block = 32 bits). The 64 bit Unique Identifier (UID) is programmed during the production process. The next 2 blocks are for control (EAS= Electronic Article Surveillance, AFI= Application Family Identifier, DSFID= Data Storage Format Identifier) and write access conditions for the rest of the blocks. Blocks 0 to 27 can be addressed with read and write commands only.

	Byte 0	Byte 1	Byte 2	Byte 3	
Block -4	UID 0	UID 1	UID 2	UID 3	} UID n° (64bits) EAS, AFI, DSFID
Block -3	UID 4	UID 5	UID 6	UID 7	
Block -2	Control bytes				
Block -1	Write access conditions				
Block 00	R/W	R/W	R/W	R/W	} User data 28 blocks
Block 01	R/W	R/W	R/W	R/W	
Block 02	R/W	R/W	R/W	R/W	
.....	
.....	
Block 25	R/W	R/W	R/W	R/W	
Block 26	R/W	R/W	R/W	R/W	
Block 27	R/W	R/W	R/W	R/W	

32 bits



FXT1.1-SLI-S

Code: 4330 034 10021

DISCLAIMER

These products are not designed for use in life support appliances, devices, or systems where malfunction of these products can reasonably be expected to result in personal injury. Ferroxcube customers using or selling these products for use in such applications do so at their own risk and agree to fully indemnify Ferroxcube for any damages resulting from such application.