

DATA SHEET

TX47/28/15

Powder material toroids

New data

2007 Jan 01

RING CORES (TOROIDS)

Effective core parameters

SYMBOL	PARAMETER	VALUE	UNIT
$\Sigma(I/A)$	core factor (C1)	0.868	mm ⁻¹
V_e	effective volume	15600	mm ³
l_e	effective length	116	mm
A_e	effective area	134	mm ²
m	mass of core (for μ_i 125)	MPP	130 g
		Sendust	95.8 g
		High-Flux	123 g

Coating

The cores are coated with epoxy. The colour is cream (Sendust), grey (MPP) or khaki (High-Flux). Maximum operating temperature is 200 °C.

Isolation voltage

AC isolation voltage : 1000 V.
 Contacts are applied on the edge of the ring core, which is also the critical point for the winding operation.

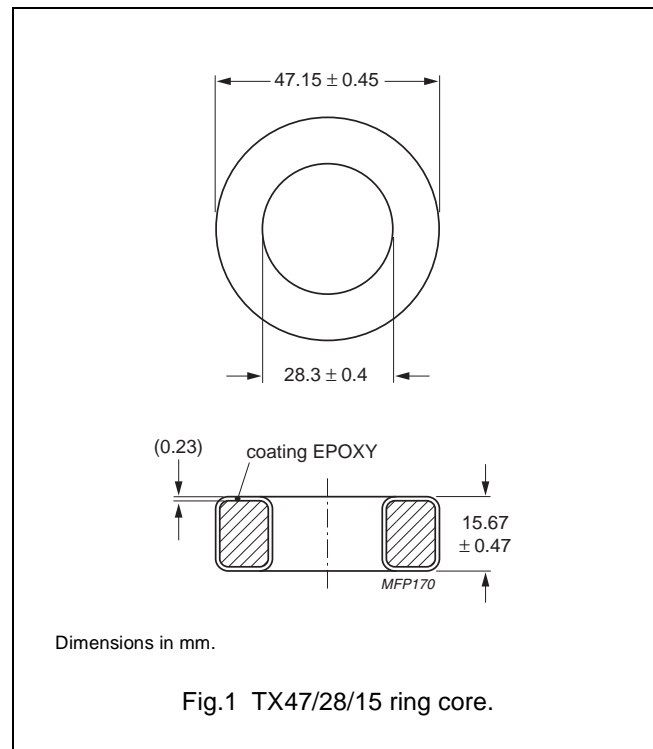

Ring core data

GRADE	A_L (nH)	μ_i	TYPE NUMBER
MPP	20 ± 8 %	14	TX47/15-M2-A20
	37 ± 8 %	26	TX47/15-M2-A37
	86 ± 8 %	60	TX47/15-M2-A86
	178 ± 8 %	125	TX47/15-M2-A178
	210 ± 8 %	147	TX47/15-M2-A210
	228 ± 8 %	160	TX47/15-M2-A228
	246 ± 8 %	173	TX47/15-M2-A248
	285 ± 8 %	200	TX47/15-M2-A285
Sendust	427 ± 8 %	300	TX47/15-M2-A427
	37 ± 8 %	26	TX47/15-S7-A37
	86 ± 8 %	60	TX47/15-S7-A86
	107 ± 8 %	75	TX47/15-S7-A107
	128 ± 8 %	90	TX47/15-S7-A128
	178 ± 8 %	125	TX47/15-S7-A178

Powder material toroids

TX47/28/15

GRADE	A_L (nH)	μ_i	TYPE NUMBER
High-Flux	$20 \pm 8 \%$	14	TX47/15-H2-A20
	$37 \pm 8 \%$	26	TX47/15-H2-A37
	$86 \pm 8 \%$	60	TX47/15-H2-A86
	$178 \pm 8 \%$	125	TX47/15-H2-A178

Properties of cores under power conditions

GRADE	μ_i	B (mT) at	CORE LOSS (W) at
		H = 100 kA/m; f = 10 kHz; T = 25 °C	f = 100 kHz; B = 100 mT; T = 25 °C
MPP	14	≥ 640	23.4
	26	≥ 700	18.7
	60	≥ 760	11.7
	125	≥ 800	11.7
	147	≥ 800	12.5
	160	≥ 800	12.5
	173	≥ 800	12.5
	200	≥ 800	23.4
	300	≥ 800	23.4
Sendust	26	≥ 1000	24.9
	60	≥ 1030	13.3
	75	≥ 1040	13.3
	90	≥ 1050	13.3
	125	≥ 1060	13.3
High-Flux	14	≥ 890	39.0
	26	≥ 980	31.2
	60	≥ 1280	28.0
	125	≥ 1370	31.2

DATA SHEET STATUS DEFINITIONS

DATA SHEET STATUS	PRODUCT STATUS	DEFINITIONS
Preliminary specification	Development	This data sheet contains preliminary data. Ferroxcube reserves the right to make changes at any time without notice in order to improve design and supply the best possible product.
Product specification	Production	This data sheet contains final specifications. Ferroxcube reserves the right to make changes at any time without notice in order to improve design and supply the best possible product.

DISCLAIMER

Life support applications — These products are not designed for use in life support appliances, devices, or systems where malfunction of these products can reasonably be expected to result in personal injury. Ferroxcube customers using or selling these products for use in such applications do so at their own risk and agree to fully indemnify Ferroxcube for any damages resulting from such application.

PRODUCT STATUS DEFINITIONS

STATUS	INDICATION	DEFINITION
Prototype		These are products that have been made as development samples for the purposes of technical evaluation only. The data for these types is provisional and is subject to change.
Design-in		These products are recommended for new designs.
Preferred		These products are recommended for use in current designs and are available via our sales channels.
Support		These products are not recommended for new designs and may not be available through all of our sales channels. Customers are advised to check for availability.