

# DATA SHEET

**TX47/24/18**

**Powder material toroids**

New data

2007 Jan 01



**FERROXCUBE**  
A YAGEO COMPANY

**RING CORES (TOROIDS)**

**Effective core parameters**

SYMBOL	PARAMETER	VALUE	UNIT
$\Sigma(I/A)$	core factor (C1)	0.540	mm <sup>-1</sup>
$V_e$	effective volume	21300	mm <sup>3</sup>
$l_e$	effective length	107	mm
$A_e$	effective area	199	mm <sup>2</sup>
m	mass of core (for $\mu_i$ 125)	MPP	181 g
		Sendust	131 g
		High-Flux	171 g

**Coating**

The cores are coated with epoxy. The colour is cream (Sendust), grey (MPP) or khaki (High-Flux). Maximum operating temperature is 200 °C.

**Isolation voltage**

AC isolation voltage : 1000 V.  
Contacts are applied on the edge of the ring core, which is also the critical point for the winding operation.

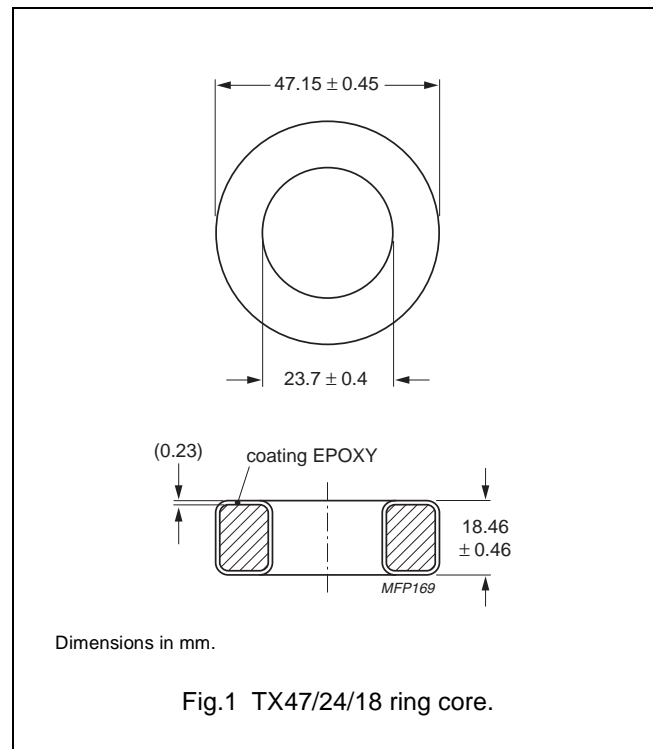

**Ring core data**

GRADE	$A_L$ (nH)	$\mu_i$	TYPE NUMBER
MPP	$32 \pm 8 \%$	14	TX47/18-M2-A32
	$59 \pm 8 \%$	26	TX47/18-M2-A59
	$135 \pm 8 \%$	60	TX47/18-M2-A135
	$281 \pm 8 \%$	125	TX47/18-M2-A281
	$330 \pm 8 \%$	147	TX47/18-M2-A330
	$360 \pm 8 \%$	160	TX47/18-M2-A360
	$390 \pm 8 \%$	173	TX47/18-M2-A390
	$450 \pm 8 \%$	200	TX47/18-M2-A450
Sendust	$674 \pm 8 \%$	300	TX47/18-M2-A674
	$59 \pm 8 \%$	26	TX47/18-S7-A59
	$135 \pm 8 \%$	60	TX47/18-S7-A135
	$169 \pm 8 \%$	75	TX47/18-S7-A169
	$202 \pm 8 \%$	90	TX47/18-S7-A202
	$281 \pm 8 \%$	125	TX47/18-S7-A281

## Powder material toroids

TX47/24/18

GRADE	$A_L$ (nH)	$\mu_i$	TYPE NUMBER
High-Flux	$32 \pm 8 \%$	14	TX47/18-H2-A32
	$59 \pm 8 \%$	26	TX47/18-H2-A59
	$135 \pm 8 \%$	60	TX47/18-H2-A135
	$281 \pm 8 \%$	125	TX47/18-H2-A281

## Properties of cores under power conditions

GRADE	$\mu_i$	B (mT) at	CORE LOSS (W) at
		H = 100 kA/m; f = 10 kHz; T = 25 °C	f = 100 kHz; B = 100 mT; T = 25 °C
MPP	14	≥ 640	32.0
	26	≥ 700	25.6
	60	≥ 760	16.0
	125	≥ 800	16.0
	147	≥ 800	17.0
	160	≥ 800	17.0
	173	≥ 800	17.0
	200	≥ 800	32.0
	300	≥ 800	32.0
Sendust	26	≥ 1000	34.1
	60	≥ 1030	18.2
	75	≥ 1040	18.2
	90	≥ 1050	18.2
	125	≥ 1060	18.2
High-Flux	14	≥ 890	53.3
	26	≥ 980	42.6
	60	≥ 1280	38.3
	125	≥ 1370	42.6

**DATA SHEET STATUS DEFINITIONS**

DATA SHEET STATUS	PRODUCT STATUS	DEFINITIONS
Preliminary specification	Development	This data sheet contains preliminary data. Ferroxcube reserves the right to make changes at any time without notice in order to improve design and supply the best possible product.
Product specification	Production	This data sheet contains final specifications. Ferroxcube reserves the right to make changes at any time without notice in order to improve design and supply the best possible product.

**DISCLAIMER**

**Life support applications** — These products are not designed for use in life support appliances, devices, or systems where malfunction of these products can reasonably be expected to result in personal injury. Ferroxcube customers using or selling these products for use in such applications do so at their own risk and agree to fully indemnify Ferroxcube for any damages resulting from such application.

**PRODUCT STATUS DEFINITIONS**

STATUS	INDICATION	DEFINITION
<b>Prototype</b>		These are products that have been made as development samples for the purposes of technical evaluation only. The data for these types is provisional and is subject to change.
<b>Design-in</b>		These products are recommended for new designs.
<b>Preferred</b>		These products are recommended for use in current designs and are available via our sales channels.
<b>Support</b>		These products are <b>not</b> recommended for new designs and may not be available through all of our sales channels. Customers are advised to check for availability.