

# DATA SHEET

**TX11/6.4/4**

**Powder material toroids**

New data

2007 Jan 01

**RING CORES (TOROIDS)**

**Effective core parameters**

SYMBOL	PARAMETER	VALUE	UNIT
$\Sigma(l/A)$	core factor (C1)	2.97	mm <sup>-1</sup>
$V_e$	effective volume	244	mm <sup>3</sup>
$l_e$	effective length	26.9	mm
$A_e$	effective area	9.06	mm <sup>2</sup>
m	mass of core (for $\mu_i$ 125)	MPP	2.12 g
		Sendust	1.50 g
		High-Flux	1.99 g

**Coating**

The cores are coated with epoxy. The colour is cream (Sendust), grey (MPP) or khaki (High-Flux). Maximum operating temperature is 200 °C. Parylene coating is also available (transparent, maximum operating temperature 130 °C).

**Isolation voltage**

AC isolation voltage : 1000 V (Parylene : 750 V).  
Contacts are applied on the edge of the ring core, which is also the critical point for the winding operation.

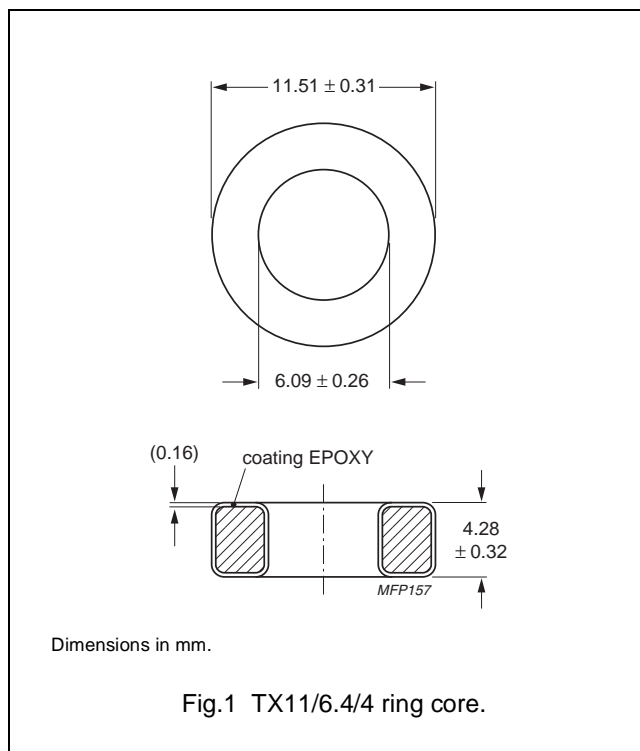

Fig.1 TX11/6.4/4 ring core.

**Ring core data**

GRADE	$A_L$ (nH)	$\mu_i$	TYPE NUMBER
MPP	$6 \pm 8 \%$	14	TX11/4-M2-A6
	$11 \pm 8 \%$	26	TX11/4-M2-A11
	$26 \pm 8 \%$	60	TX11/4-M2-A26
	$53 \pm 8 \%$	125	TX11/4-M2-A53
	$63 \pm 8 \%$	147	TX11/4-M2-A63
	$68 \pm 8 \%$	160	TX11/4-M2-A68
	$74 \pm 8 \%$	173	TX11/4-M2-A74
	$85 \pm 8 \%$	200	TX11/4-M2-A85
Sendust	$127 \pm 8 \%$	300	TX11/4-M2-A127
	$26 \pm 12 \%$	60	TX11/4-S7-A26
	$32 \pm 12 \%$	75	TX11/4-S7-A32
	$38 \pm 12 \%$	90	TX11/4-S7-A38
	$53 \pm 12 \%$	125	TX11/4-S7-A53

## Powder material toroids

TX11/6.4/4

GRADE	$A_L$ (nH)	$\mu_i$	TYPE NUMBER
High-Flux	$6 \pm 8 \%$	14	TX11/4-H2-A6
	$11 \pm 8 \%$	26	TX11/4-H2-A11
	$26 \pm 8 \%$	60	TX11/4-H2-A26
	$53 \pm 8 \%$	125	TX11/4-H2-A53
	$63 \pm 8 \%$	147	TX11/4-H2-A63
	$68 \pm 8 \%$	160	TX11/4-H2-A68

## Properties of cores under power conditions

GRADE	$\mu_i$	B (mT) at	CORE LOSS (W) at
		H = 100 kA/m; f = 10 kHz; T = 25 °C	f = 100 kHz; $\hat{B} = 100$ mT; T = 25 °C
MPP	14	$\geq 640$	0.366
	26	$\geq 700$	0.292
	60	$\geq 760$	0.183
	125	$\geq 800$	0.183
	147	$\geq 800$	0.195
	160	$\geq 800$	0.195
	173	$\geq 800$	0.195
	200	$\geq 800$	0.366
	300	$\geq 800$	0.366
Sendust	60	$\geq 1030$	0.208
	75	$\geq 1040$	0.208
	90	$\geq 1050$	0.208
	125	$\geq 1060$	0.208
High-Flux	14	$\geq 890$	0.609
	26	$\geq 980$	0.487
	60	$\geq 1280$	0.439
	125	$\geq 1370$	0.487
	147	$\geq 1385$	0.536
	160	$\geq 1400$	0.853

**DATA SHEET STATUS DEFINITIONS**

DATA SHEET STATUS	PRODUCT STATUS	DEFINITIONS
Preliminary specification	Development	This data sheet contains preliminary data. Ferroxcube reserves the right to make changes at any time without notice in order to improve design and supply the best possible product.
Product specification	Production	This data sheet contains final specifications. Ferroxcube reserves the right to make changes at any time without notice in order to improve design and supply the best possible product.

**DISCLAIMER**

**Life support applications** — These products are not designed for use in life support appliances, devices, or systems where malfunction of these products can reasonably be expected to result in personal injury. Ferroxcube customers using or selling these products for use in such applications do so at their own risk and agree to fully indemnify Ferroxcube for any damages resulting from such application.

**PRODUCT STATUS DEFINITIONS**

STATUS	INDICATION	DEFINITION
<b>Prototype</b>		These are products that have been made as development samples for the purposes of technical evaluation only. The data for these types is provisional and is subject to change.
<b>Design-in</b>		These products are recommended for new designs.
<b>Preferred</b>		These products are recommended for use in current designs and are available via our sales channels.
<b>Support</b>		These products are <b>not</b> recommended for new designs and may not be available through all of our sales channels. Customers are advised to check for availability.