

# DATA SHEET

**TX9.7/4.8/4**

**Powder material toroids**

New data

2007 Jan 01



**FERROXCUBE**  
A YAGEO COMPANY

**RING CORES (TOROIDS)**

**Effective core parameters**

SYMBOL	PARAMETER	VALUE	UNIT	
$\Sigma(l/A)$	core factor (C1)	2.31	mm <sup>-1</sup>	
$V_e$	effective volume	206	mm <sup>3</sup>	
$l_e$	effective length	21.8	mm	
$A_e$	effective area	9.45	mm <sup>2</sup>	
m	mass of core (for $\mu_i$ 125)	MPP	1.80	g
		Sendust	1.44	g
		High-Flux	1.70	g

**Coating**

The cores are coated with epoxy. The colour is cream (Sendust), grey (MPP) or khaki (High-Flux). Maximum operating temperature is 200 °C. Parylene coating is also available (transparent, maximum operating temperature 130 °C).

**Isolation voltage**

AC isolation voltage : 1000 V (Parylene : 750 V).  
Contacts are applied on the edge of the ring core, which is also the critical point for the winding operation.

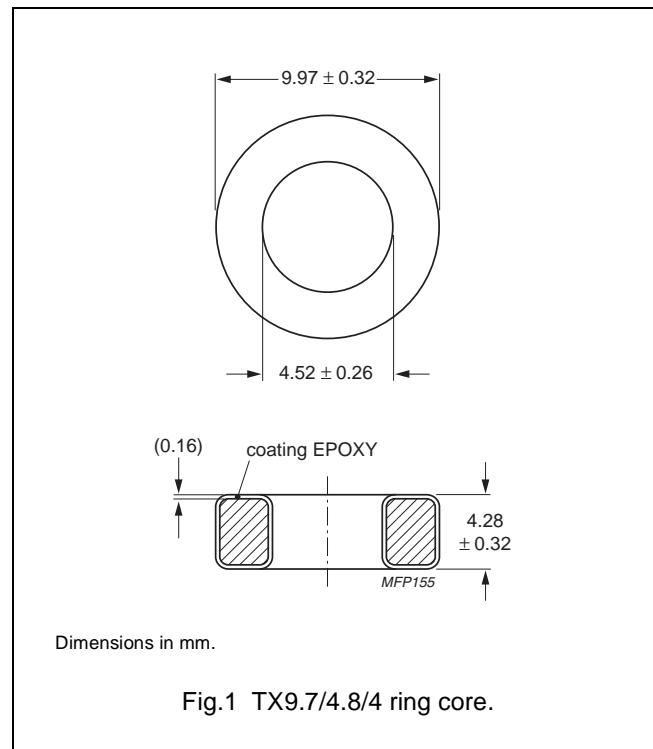

**Ring core data**

GRADE	$A_L$ (nH)	$\mu_i$	TYPE NUMBER
MPP	7 ± 8 %	14	TX9.7/4-M2-A7
	14 ± 8 %	26	TX9.7/4-M2-A14
	32 ± 8 %	60	TX9.7/4-M2-A32
	66 ± 8 %	125	TX9.7/4-M2-A66
	78 ± 8 %	147	TX9.7/4-M2-A78
	84 ± 8 %	160	TX9.7/4-M2-A84
	92 ± 8 %	173	TX9.7/4-M2-A92
	105 ± 8 %	200	TX9.7/4-M2-A105
Sendust	159 ± 8 %	300	TX9.7/4-M2-A159
	32 ± 12 %	60	TX9.7/4-S7-A32
	40 ± 12 %	75	TX9.7/4-S7-A40
	48 ± 12 %	90	TX9.7/4-S7-A48
	66 ± 12 %	125	TX9.7/4-S7-A66

## Powder material toroids

TX9.7/4.8/4

GRADE	$A_L$ (nH)	$\mu_i$	TYPE NUMBER
High-Flux	$7 \pm 8 \%$	14	TX9.7/4-H2-A7
	$14 \pm 8 \%$	26	TX9.7/4-H2-A14
	$32 \pm 8 \%$	60	TX9.7/4-H2-A32
	$66 \pm 8 \%$	125	TX9.7/4-H2-A66
	$78 \pm 8 \%$	147	TX9.7/4-H2-A78
	$84 \pm 8 \%$	160	TX9.7/4-H2-A84

## Properties of cores under power conditions

GRADE	$\mu_i$	B (mT) at	CORE LOSS (W) at
		H = 100 kA/m; f = 10 kHz; T = 25 °C	f = 100 kHz; $\hat{B} = 100$ mT; T = 25 °C
MPP	14	$\geq 640$	0.309
	26	$\geq 700$	0.247
	60	$\geq 760$	0.155
	125	$\geq 800$	0.155
	147	$\geq 800$	0.165
	160	$\geq 800$	0.165
	173	$\geq 800$	0.165
	200	$\geq 800$	0.309
	300	$\geq 800$	0.309
Sendust	60	$\geq 1030$	0.176
	75	$\geq 1040$	0.176
	90	$\geq 1050$	0.176
	125	$\geq 1060$	0.176
High-Flux	14	$\geq 890$	0.515
	26	$\geq 980$	0.412
	60	$\geq 1280$	0.371
	125	$\geq 1370$	0.412
	147	$\geq 1385$	0.451
	160	$\geq 1400$	0.721

**DATA SHEET STATUS DEFINITIONS**

DATA SHEET STATUS	PRODUCT STATUS	DEFINITIONS
Preliminary specification	Development	This data sheet contains preliminary data. Ferroxcube reserves the right to make changes at any time without notice in order to improve design and supply the best possible product.
Product specification	Production	This data sheet contains final specifications. Ferroxcube reserves the right to make changes at any time without notice in order to improve design and supply the best possible product.

**DISCLAIMER**

**Life support applications** — These products are not designed for use in life support appliances, devices, or systems where malfunction of these products can reasonably be expected to result in personal injury. Ferroxcube customers using or selling these products for use in such applications do so at their own risk and agree to fully indemnify Ferroxcube for any damages resulting from such application.

**PRODUCT STATUS DEFINITIONS**

STATUS	INDICATION	DEFINITION
<b>Prototype</b>		These are products that have been made as development samples for the purposes of technical evaluation only. The data for these types is provisional and is subject to change.
<b>Design-in</b>		These products are recommended for new designs.
<b>Preferred</b>		These products are recommended for use in current designs and are available via our sales channels.
<b>Support</b>		These products are <b>not</b> recommended for new designs and may not be available through all of our sales channels. Customers are advised to check for availability.