

DATA SHEET

TX7.9/4/3.2

Powder material toroids

New data

2007 Jan 01



FERROXCUBE
A YAGEO COMPANY

RING CORES (TOROIDS)

Effective core parameters

SYMBOL	PARAMETER	VALUE	UNIT
$\Sigma(I/A)$	core factor (C1)	2.91	mm ⁻¹
V_e	effective volume	110	mm ³
l_e	effective length	17.9	mm
A_e	effective area	6.15	mm ²
m	mass of core (for μ_i 125)	MPP	0.92 g
		Sendust	0.68 g
		High-Flux	0.87 g

Coating

The cores are coated with epoxy. The colour is cream (Sendust), grey (MPP) or khaki (High-Flux). Maximum operating temperature is 200 °C. Parylene coating is also available (transparent, maximum operating temperature 130 °C).

Isolation voltage

AC isolation voltage : 1000 V (Parylene : 750 V).
Contacts are applied on the edge of the ring core, which is also the critical point for the winding operation.

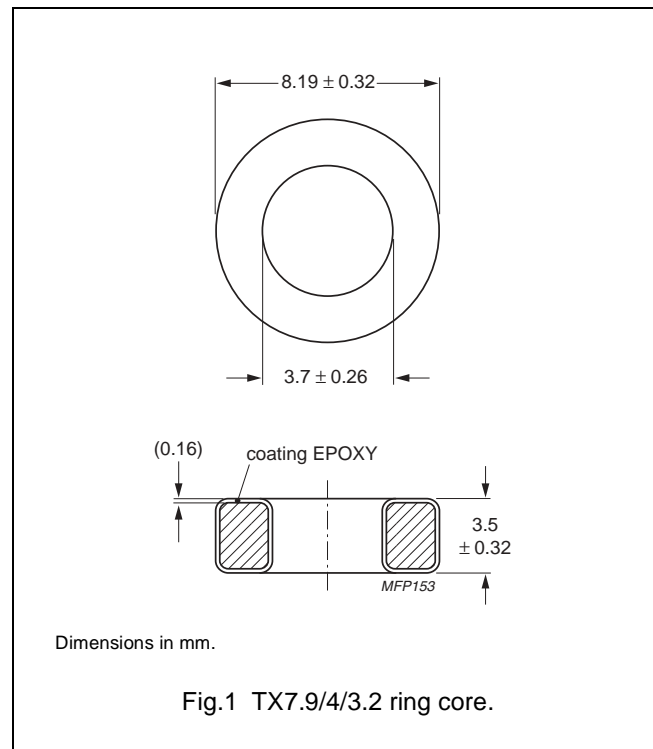

Fig.1 TX7.9/4/3.2 ring core.

Ring core data

GRADE	A_L (nH)	μ_i	TYPE NUMBER
MPP	$6 \pm 8 \%$	14	TX7.9/3.2-M2-A6
	$11 \pm 8 \%$	26	TX7.9/3.2-M2-A11
	$25 \pm 8 \%$	60	TX7.9/3.2-M2-A25
	$52 \pm 8 \%$	125	TX7.9/3.2-M2-A52
	$62 \pm 8 \%$	147	TX7.9/3.2-M2-A62
	$66 \pm 8 \%$	160	TX7.9/3.2-M2-A66
	$73 \pm 8 \%$	173	TX7.9/3.2-M2-A73
	$83 \pm 8 \%$	200	TX7.9/3.2-M2-A83
Sendust	$124 \pm 8 \%$	300	TX7.9/3.2-M2-A124
	$25 \pm 12 \%$	60	TX7.9/3.2-S7-A25
	$31 \pm 12 \%$	75	TX7.9/3.2-S7-A31
	$37 \pm 12 \%$	90	TX7.9/3.2-S7-A37
	$52 \pm 12 \%$	125	TX7.9/3.2-S7-A52

Powder material toroids

TX7.9/4/3.2

GRADE	A_L (nH)	μ_i	TYPE NUMBER
High-Flux	$6 \pm 8 \%$	14	TX7.9/3.2-H2-A6
	$11 \pm 8 \%$	26	TX7.9/3.2-H2-A11
	$25 \pm 8 \%$	60	TX7.9/3.2-H2-A25
	$52 \pm 8 \%$	125	TX7.9/3.2-H2-A52
	$62 \pm 8 \%$	147	TX7.9/3.2-H2-A62
	$66 \pm 8 \%$	160	TX7.9/3.2-H2-A66

Properties of cores under power conditions

GRADE	μ_i	B (mT) at	CORE LOSS (W) at
		H = 100 kA/m; f = 10 kHz; T = 25 °C	f = 100 kHz; $\hat{B} = 100$ mT; T = 25 °C
MPP	14	≥ 640	0.165
	26	≥ 700	0.132
	60	≥ 760	0.082
	125	≥ 800	0.082
	147	≥ 800	0.088
	160	≥ 800	0.088
	173	≥ 800	0.088
	200	≥ 800	0.165
	300	≥ 800	0.165
Sendust	60	≥ 1030	0.094
	75	≥ 1040	0.094
	90	≥ 1050	0.094
	125	≥ 1060	0.094
High-Flux	14	≥ 890	0.275
	26	≥ 980	0.220
	60	≥ 1280	0.198
	125	≥ 1370	0.220
	147	≥ 1385	0.242
	160	≥ 1400	0.385

DATA SHEET STATUS DEFINITIONS

DATA SHEET STATUS	PRODUCT STATUS	DEFINITIONS
Preliminary specification	Development	This data sheet contains preliminary data. Ferroxcube reserves the right to make changes at any time without notice in order to improve design and supply the best possible product.
Product specification	Production	This data sheet contains final specifications. Ferroxcube reserves the right to make changes at any time without notice in order to improve design and supply the best possible product.

DISCLAIMER

Life support applications — These products are not designed for use in life support appliances, devices, or systems where malfunction of these products can reasonably be expected to result in personal injury. Ferroxcube customers using or selling these products for use in such applications do so at their own risk and agree to fully indemnify Ferroxcube for any damages resulting from such application.

PRODUCT STATUS DEFINITIONS

STATUS	INDICATION	DEFINITION
Prototype		These are products that have been made as development samples for the purposes of technical evaluation only. The data for these types is provisional and is subject to change.
Design-in		These products are recommended for new designs.
Preferred		These products are recommended for use in current designs and are available via our sales channels.
Support		These products are not recommended for new designs and may not be available through all of our sales channels. Customers are advised to check for availability.