

DATA SHEET

TX6.4/2.8/2.8

Powder material toroids

New data

2007 Jan 01

RING CORES (TOROIDS)

Effective core parameters

SYMBOL	PARAMETER	VALUE	UNIT
$\Sigma(l/A)$	core factor (C1)	2.90	mm ⁻¹
V_e	effective volume	64.0	mm ³
l_e	effective length	13.6	mm
A_e	effective area	4.70	mm ²
m	mass of core (for μ_i 125)	MPP	0.59 g
		Sendust	0.39 g
		High-Flux	0.55 g

Coating

The cores are coated with epoxy. The colour is cream (Sendust), grey (MPP) or khaki (High-Flux). Maximum operating temperature is 200 °C. Parylene coating is also available (transparent, maximum operating temperature 130 °C).

Isolation voltage

AC isolation voltage : 1000 V (Parylene : 750 V).
Contacts are applied on the edge of the ring core, which is also the critical point for the winding operation.

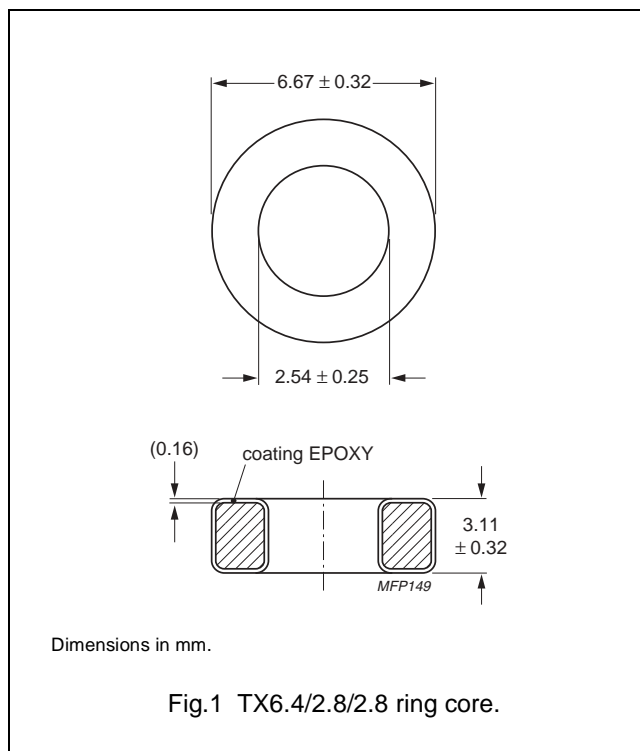

Ring core data

GRADE	A_L (nH)	μ_i	TYPE NUMBER
MPP	6 ± 8 %	14	TX6.4/2.8-M2-A6
	10 ± 8 %	26	TX6.4/2.8-M2-A10
	24 ± 8 %	60	TX6.4/2.8-M2-A24
	50 ± 8 %	125	TX6.4/2.8-M2-A50
	59 ± 8 %	147	TX6.4/2.8-M2-A59
	64 ± 8 %	160	TX6.4/2.8-M2-A64
	69 ± 8 %	173	TX6.4/2.8-M2-A69
	80 ± 8 %	200	TX6.4/2.8-M2-A80
Sendust	120 ± 8 %	300	TX6.4/2.8-M2-A120
	24 ± 12 %	60	TX6.4/2.8-S7-A24
	30 ± 12 %	75	TX6.4/2.8-S7-A30
	36 ± 12 %	90	TX6.4/2.8-S7-A36
	50 ± 12 %	125	TX6.4/2.8-S7-A50

Powder material toroids

TX6.4/2.8/2.8

GRADE	A_L (nH)	μ_i	TYPE NUMBER
High-Flux	$6 \pm 8 \%$	14	TX6.4/2.8-H2-A6
	$10 \pm 8 \%$	26	TX6.4/2.8-H2-A10
	$24 \pm 8 \%$	60	TX6.4/2.8-H2-A24
	$50 \pm 8 \%$	125	TX6.4/2.8-H2-A50
	$59 \pm 8 \%$	147	TX6.4/2.8-H2-A59
	$64 \pm 8 \%$	160	TX6.4/2.8-H2-A64

Properties of cores under power conditions

GRADE	μ_i	B (mT) at	CORE LOSS (W) at
		H = 100 kA/m; f = 10 kHz; T = 25 °C	f = 100 kHz; $\hat{B} = 100$ mT; T = 25 °C
MPP	14	≥ 640	0.096
	26	≥ 700	0.077
	60	≥ 760	0.048
	125	≥ 800	0.048
	147	≥ 800	0.051
	160	≥ 800	0.051
	173	≥ 800	0.051
	200	≥ 800	0.096
	300	≥ 800	0.096
Sendust	60	≥ 1030	0.055
	75	≥ 1040	0.055
	90	≥ 1050	0.055
	125	≥ 1060	0.055
High-Flux	14	≥ 890	0.160
	26	≥ 980	0.128
	60	≥ 1280	0.115
	125	≥ 1370	0.128
	147	≥ 1385	0.141
	160	≥ 1400	0.224

DATA SHEET STATUS DEFINITIONS

DATA SHEET STATUS	PRODUCT STATUS	DEFINITIONS
Preliminary specification	Development	This data sheet contains preliminary data. Ferroxcube reserves the right to make changes at any time without notice in order to improve design and supply the best possible product.
Product specification	Production	This data sheet contains final specifications. Ferroxcube reserves the right to make changes at any time without notice in order to improve design and supply the best possible product.

DISCLAIMER

Life support applications — These products are not designed for use in life support appliances, devices, or systems where malfunction of these products can reasonably be expected to result in personal injury. Ferroxcube customers using or selling these products for use in such applications do so at their own risk and agree to fully indemnify Ferroxcube for any damages resulting from such application.

PRODUCT STATUS DEFINITIONS

STATUS	INDICATION	DEFINITION
Prototype		These are products that have been made as development samples for the purposes of technical evaluation only. The data for these types is provisional and is subject to change.
Design-in		These products are recommended for new designs.
Preferred		These products are recommended for use in current designs and are available via our sales channels.
Support		These products are not recommended for new designs and may not be available through all of our sales channels. Customers are advised to check for availability.