

DATA SHEET

TX57/36/14

Powder material toroids

New data

2007 Jan 01



FERROXCUBE
A YAGEO COMPANY

RING CORES (TOROIDS)

Effective core parameters

SYMBOL	PARAMETER	VALUE	UNIT
$\Sigma(l/A)$	core factor (C1)	0.990	mm ⁻¹
V_e	effective volume	20650	mm ³
l_e	effective length	143	mm
A_e	effective area	144	mm ²
m	mass of core (for μ_i 125)	MPP	175 g
		Sendust	127 g
		High-Flux	165 g

Coating

The cores are coated with epoxy. The colour is cream (Sendust), grey (MPP) or khaki (High-Flux). Maximum operating temperature is 200 °C.

Isolation voltage

AC isolation voltage : 1000 V.
Contacts are applied on the edge of the ring core, which is also the critical point for the winding operation.

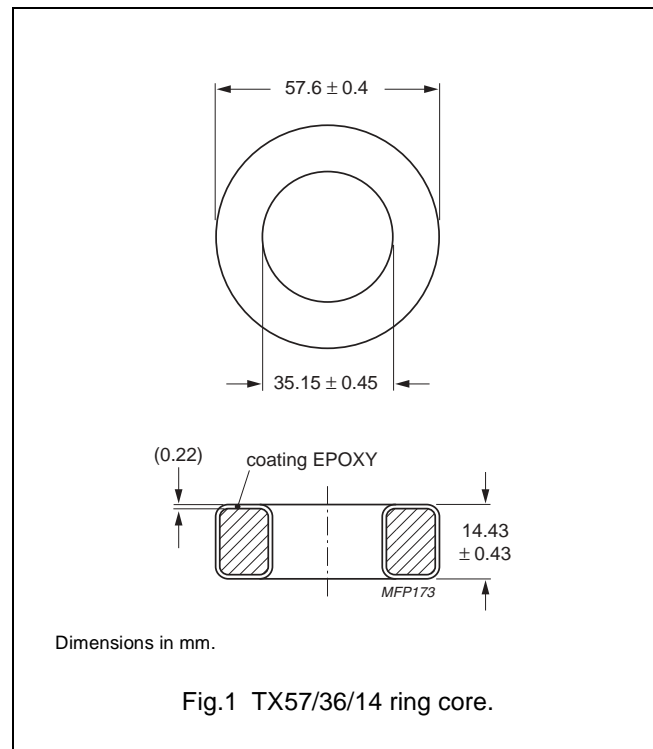

Ring core data

GRADE	A_L (nH)	μ_i	TYPE NUMBER
MPP	18 ± 8 %	14	TX57/14-M2-A18
	33 ± 8 %	26	TX57/14-M2-A33
	75 ± 8 %	60	TX57/14-M2-A75
	156 ± 8 %	125	TX57/14-M2-A156
	185 ± 8 %	147	TX57/14-M2-A185
	200 ± 8 %	160	TX57/14-M2-A200
	218 ± 8 %	173	TX57/14-M2-A218
	250 ± 8 %	200	TX57/14-M2-A250
Sendust	374 ± 8 %	300	TX57/14-M2-A374
	33 ± 8 %	26	TX57/14-S7-A33
	75 ± 8 %	60	TX57/14-S7-A75
	94 ± 8 %	75	TX57/14-S7-A94
	112 ± 8 %	90	TX57/14-S7-A112
	156 ± 8 %	125	TX57/14-S7-A156

Powder material toroids

TX57/36/14

GRADE	A_L (nH)	μ_i	TYPE NUMBER
High-Flux	$18 \pm 8 \%$	14	TX57/14-H2-A18
	$33 \pm 8 \%$	26	TX57/14-H2-A33
	$75 \pm 8 \%$	60	TX57/14-H2-A75
	$156 \pm 8 \%$	125	TX57/14-H2-A156

Properties of cores under power conditions

GRADE	μ_i	B (mT) at	CORE LOSS (W) at
		H = 100 kA/m; f = 10 kHz; T = 25 °C	f = 100 kHz; B = 100 mT; T = 25 °C
MPP	14	≥ 640	31.0
	26	≥ 700	24.8
	60	≥ 760	15.5
	125	≥ 800	15.5
	147	≥ 800	16.5
	160	≥ 800	16.5
	173	≥ 800	16.5
	200	≥ 800	31.0
	300	≥ 800	31.0
Sendust	26	≥ 1000	33.0
	60	≥ 1030	17.7
	75	≥ 1040	17.7
	90	≥ 1050	17.7
	125	≥ 1060	17.7
High-Flux	14	≥ 890	51.6
	26	≥ 980	41.3
	60	≥ 1280	37.2
	125	≥ 1370	41.3

DATA SHEET STATUS DEFINITIONS

DATA SHEET STATUS	PRODUCT STATUS	DEFINITIONS
Preliminary specification	Development	This data sheet contains preliminary data. Ferroxcube reserves the right to make changes at any time without notice in order to improve design and supply the best possible product.
Product specification	Production	This data sheet contains final specifications. Ferroxcube reserves the right to make changes at any time without notice in order to improve design and supply the best possible product.

DISCLAIMER

Life support applications — These products are not designed for use in life support appliances, devices, or systems where malfunction of these products can reasonably be expected to result in personal injury. Ferroxcube customers using or selling these products for use in such applications do so at their own risk and agree to fully indemnify Ferroxcube for any damages resulting from such application.

PRODUCT STATUS DEFINITIONS

STATUS	INDICATION	DEFINITION
Prototype		These are products that have been made as development samples for the purposes of technical evaluation only. The data for these types is provisional and is subject to change.
Design-in		These products are recommended for new designs.
Preferred		These products are recommended for use in current designs and are available via our sales channels.
Support		These products are not recommended for new designs and may not be available through all of our sales channels. Customers are advised to check for availability.