

DATA SHEET

TX3.6/1.8/1.5
Powder material toroids

New data

2007 Jan 01

RING CORES (TOROIDS)

Effective core parameters

SYMBOL	PARAMETER	VALUE	UNIT	
$\Sigma(l/A)$	core factor (C1)	5.96	mm ⁻¹	
V_e	effective volume	11.2	mm ³	
l_e	effective length	8.17	mm	
A_e	effective area	1.37	mm ²	
m	mass of core (for μ_i 125)	MPP	0.09	g
		Sendust	0.07	g

Coating

The cores are coated with epoxy. The colour is cream (Sendust), grey (MPP) or khaki (High-Flux). Maximum operating temperature is 200 °C. Parylene coating is also available (transparent, maximum operating temperature 130 °C).

Isolation voltage

AC isolation voltage : 1000 V (Parylene : 750 V). Contacts are applied on the edge of the ring core, which is also the critical point for the winding operation.

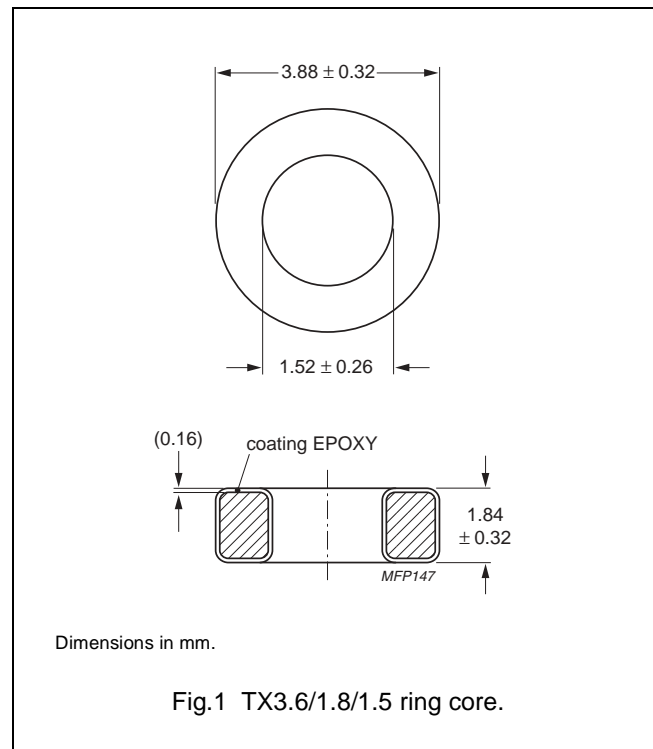

Ring core data

GRADE	A_L (nH)	μ_i	TYPE NUMBER
MPP	26 ± 8 %	125	TX3.6/1.5-M2-A26
	31 ± 8 %	147	TX3.6/1.5-M2-A31
	33 ± 8 %	160	TX3.6/1.5-M2-A33
	36 ± 8 %	173	TX3.6/1.5-M2-A36
	42 ± 8 %	200	TX3.6/1.5-M2-A42
	62 ± 8 %	300	TX3.6/1.5-M2-A62
Sendust	13 ± 15 %	60	TX3.6/1.5-S7-A13
	16 ± 15 %	75	TX3.6/1.5-S7-A16
	19 ± 15 %	90	TX3.6/1.5-S7-A19
	26 ± 15 %	125	TX3.6/1.5-S7-A26

Properties of cores under power conditions

GRADE	μ_i	B (mT) at	CORE LOSS (W) at
		H = 100 kA/m; f = 10 kHz; T = 25 °C	f = 100 kHz; \hat{B} = 100 mT; T = 25 °C
MPP	125	≥ 800	0.008
	147	≥ 800	0.009
	160	≥ 800	0.009
	173	≥ 800	0.009
	200	≥ 800	0.017
	300	≥ 800	0.017
Sendust	60	≥ 1030	0.010
	75	≥ 1040	0.010
	90	≥ 1050	0.010
	125	≥ 1060	0.010

DATA SHEET STATUS DEFINITIONS

DATA SHEET STATUS	PRODUCT STATUS	DEFINITIONS
Preliminary specification	Development	This data sheet contains preliminary data. Ferroxcube reserves the right to make changes at any time without notice in order to improve design and supply the best possible product.
Product specification	Production	This data sheet contains final specifications. Ferroxcube reserves the right to make changes at any time without notice in order to improve design and supply the best possible product.

DISCLAIMER

Life support applications — These products are not designed for use in life support appliances, devices, or systems where malfunction of these products can reasonably be expected to result in personal injury. Ferroxcube customers using or selling these products for use in such applications do so at their own risk and agree to fully indemnify Ferroxcube for any damages resulting from such application.

PRODUCT STATUS DEFINITIONS

STATUS	INDICATION	DEFINITION
Prototype		These are products that have been made as development samples for the purposes of technical evaluation only. The data for these types is provisional and is subject to change.
Design-in		These products are recommended for new designs.
Preferred		These products are recommended for use in current designs and are available via our sales channels.
Support		These products are not recommended for new designs and may not be available through all of our sales channels. Customers are advised to check for availability.