

DATA SHEET

TX20/13/6.4

Powder material toroids

New data

2007 Jan 01

RING CORES (TOROIDS)

Effective core parameters

SYMBOL	PARAMETER	VALUE	UNIT
$\Sigma(l/A)$	core factor (C1)	2.25	mm ⁻¹
V_e	effective volume	1150	mm ³
l_e	effective length	50.9	mm
A_e	effective area	22.6	mm ²
m	mass of core (for μ_i 125)	MPP	9.40 g
		Sendust	7.10 g
		High-Flux	8.90 g

Coating

The cores are coated with epoxy. The colour is cream (Sendust), grey (MPP) or khaki (High-Flux). Maximum operating temperature is 200 °C.

Isolation voltage

AC isolation voltage : 1000 V.
Contacts are applied on the edge of the ring core, which is also the critical point for the winding operation.

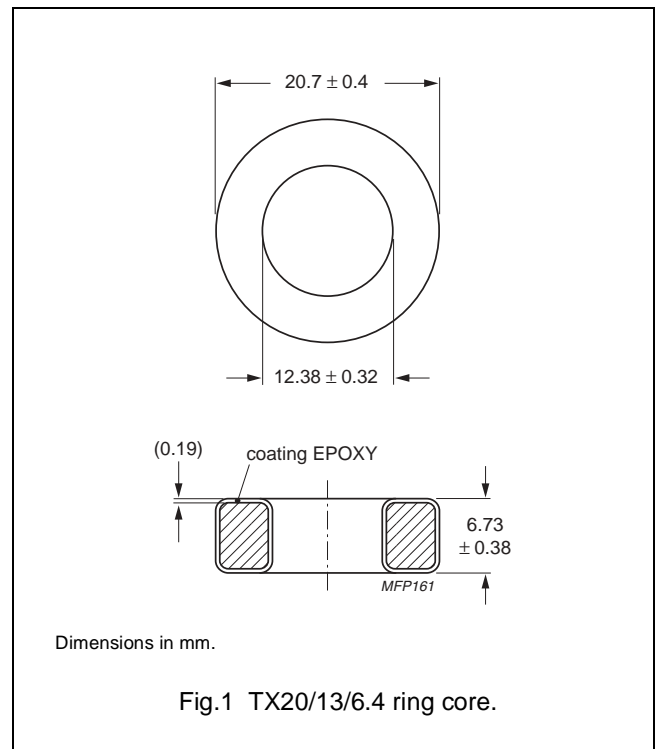

Ring core data

GRADE	A_L (nH)	μ_i	TYPE NUMBER
MPP	$7.8 \pm 8 \%$	14	TX20/6.4-M2-A7.8
	$14 \pm 8 \%$	26	TX20/6.4-M2-A14
	$32 \pm 8 \%$	60	TX20/6.4-M2-A32
	$68 \pm 8 \%$	125	TX20/6.4-M2-A68
	$81 \pm 8 \%$	147	TX20/6.4-M2-A81
	$87 \pm 8 \%$	160	TX20/6.4-M2-A87
	$109 \pm 8 \%$	200	TX20/6.4-M2-A109
Sendust	$163 \pm 8 \%$	300	TX20/6.4-M2-A163
	$32 \pm 8 \%$	60	TX20/6.4-S7-A32
	$41 \pm 8 \%$	75	TX20/6.4-S7-A41
	$49 \pm 8 \%$	90	TX20/6.4-S7-A49
	$68 \pm 8 \%$	125	TX20/6.4-S7-A68

Powder material toroids

TX20/13/6.4

GRADE	A_L (nH)	μ_i	TYPE NUMBER
High-Flux	$7.8 \pm 8 \%$	14	TX20/6.4-H2-A7.8
	$14 \pm 8 \%$	26	TX20/6.4-H2-A14
	$32 \pm 8 \%$	60	TX20/6.4-H2-A32
	$68 \pm 8 \%$	125	TX20/6.4-H2-A68
	$81 \pm 8 \%$	147	TX20/6.4-H2-A81
	$87 \pm 8 \%$	160	TX20/6.4-H2-A87

Properties of cores under power conditions

GRADE	μ_i	B (mT) at	CORE LOSS (W) at
		H = 100 kA/m; f = 10 kHz; T = 25 °C	f = 100 kHz; $\hat{B} = 100$ mT; T = 25 °C
MPP	14	≥ 640	1.73
	26	≥ 700	1.38
	60	≥ 760	0.863
	125	≥ 800	0.863
	147	≥ 800	0.920
	160	≥ 800	0.920
	200	≥ 800	1.73
	300	≥ 800	1.73
Sendust	60	≥ 1030	0.983
	75	≥ 1040	0.983
	90	≥ 1050	0.983
	125	≥ 1060	0.983
High-Flux	14	≥ 890	2.88
	26	≥ 980	2.30
	60	≥ 1280	2.07
	125	≥ 1370	2.30
	147	≥ 1385	2.53
	160	≥ 1400	4.03

DATA SHEET STATUS DEFINITIONS

DATA SHEET STATUS	PRODUCT STATUS	DEFINITIONS
Preliminary specification	Development	This data sheet contains preliminary data. Ferroxcube reserves the right to make changes at any time without notice in order to improve design and supply the best possible product.
Product specification	Production	This data sheet contains final specifications. Ferroxcube reserves the right to make changes at any time without notice in order to improve design and supply the best possible product.

DISCLAIMER

Life support applications — These products are not designed for use in life support appliances, devices, or systems where malfunction of these products can reasonably be expected to result in personal injury. Ferroxcube customers using or selling these products for use in such applications do so at their own risk and agree to fully indemnify Ferroxcube for any damages resulting from such application.

PRODUCT STATUS DEFINITIONS

STATUS	INDICATION	DEFINITION
Prototype		These are products that have been made as development samples for the purposes of technical evaluation only. The data for these types is provisional and is subject to change.
Design-in		These products are recommended for new designs.
Preferred		These products are recommended for use in current designs and are available via our sales channels.
Support		These products are not recommended for new designs and may not be available through all of our sales channels. Customers are advised to check for availability.